

# **LEARJET PRODUCT HISTORY**

**2 December 1996**

The information contained in this training/reference material is not intended to take the place of information found in Learjet drawings, Instructions, Standards or Procedures in the Learjet Service Manuals, Maintenance Manuals, Learjet NDI Manual or FAA Regulations.

## Table of Contents

Table of Contents.....	2
MODEL 23.....	3
MODEL 23/24 CONVERSION .....	3
MODEL 24 / 24A.....	4
MODEL 24B / 24B-A.....	4
MODEL 24D.....	5
MODEL 24E.....	5
MODEL 24F.....	6
MODEL 25.....	7
MODEL 25B/C.....	7
MODEL 25D/F.....	8
MODEL 25G.....	9
MODEL 28.....	9
MODEL 29.....	9
MODEL 31.....	10
MODEL 31A.....	10
MODEL 35.....	10
MODEL 35A.....	11
USAF C-21A.....	11
MODEL 36.....	12
MODEL 36A.....	12
MODEL 55.....	13
MODEL 55B.....	13
MODEL 55C.....	14
MODEL 60.....	14
LEARJET WINGS and WING MODIFICATIONS.....	15
MODIFICATIONS TO THE LEARJET AIRCRAFT.....	24
AIRCRAFT SERIALIZATION.....	26

## MODEL 23

(12,499 GTOW)

S/N 23-001 thru 23-099

A total of **104** Model 23 aircraft were built. The five (5) extra aircraft carry an "A" after the serial number. The extra aircraft are; 028A, 045A, 050A, 065A, 082A.

Original design taken from a Swiss "P-16" fighter.

First flown October 7, 1963; Certified in July 1964.

*Certified as a Part 23 aircraft.*

### Notable features:

Tip tanks point up.

Vortex generators on the top and bottom surface of wing, no strake on tip tank.

Large cabin windows.

Fiberglass engine inlets.

Bullet nose on vertical.

Two pane windshield.

Most switches on pilot's side of cockpit for proposed single pilot.

IDC cabin controller 41,000 ft.

Electric fuel pumps.

Cross flow by gravity feed.

Air conditioner in cabinet behind pilot.

General Electric CJ610-1 Engines (2850 lbs of thrust).

Single Flap Actuator.

### Changes in model series:

23-015 Moved switches to copilot's side for two pilot configuration.

23-030 General Electric CJ610-4 engine (accessories under frame).

23-070 Electric pump added to fuel cross flow.

23-080 Aluminum engine nacelle inlets.

23-090 Dual flap actuators.

## MODEL 23/24 CONVERSION

Aircraft converted to Model 24 *configuration* by Engineering Change Records (ECR's):

ECR **227** (23-070 thru 23-099), ECR **230** (23-040 thru 23-069), and ECR **233** (23-003 - 23-039).

A total of 13 conversions completed.

Serial Numbers: 23-011, 012, 015, 019, 031, 043, 050, 051, 055, 060, 065, 087, 096

There will be a Model 23 Data Plate *and* a Model 24 Conversion Data Plate, in nose wheel well.

The "Certificate of Airworthiness" will read 23/24

23-015 (ECR 277) and 23-019 (ECR 381) *are not* complete Model 24 modifications.

- Need engine fire bottles to complete modification.

## MODEL 24 / 24A

(13,000 GTOW)  
(12,499 GTOW - 24A)

S/N 24-100 thru 24-180

Certified in March 1966.

*Certified as a Part 25 aircraft.*

24A models restricted to 12,499 lbs.

### Notable features:

- Solid (one piece) windshield with bird splitter (305 knot).
- Engine fire bottles.
- Goodyear brakes.
- Windshield alcohol system added to both Pilot and Co-Pilot windshield.
- Jet pumps in wing and tips.
- M<sub>MO</sub> puller system added.
- Vortex generators on top of wing only, tip tank strake added.

### Changes in model series:

- 24-130 Moved the air conditioner to baggage compartment.  
Minimum Electric System Modification (Mini-Mod.).
  - Prior aircraft required by A.D. Note (ECR 340).
- 24-140 Certified to 45,000 ft; added down spring and bob weight to flight control system.  
Pitch and Yaw servos moved from Frame 26.  
Wing heat began as optional equipment.
  - Offered as retrofit on all aircraft.
  - Wing heat **did not** make the aircraft "all weather".
- 24-156 Annunciator panel moved to glareshield.

**Wing heat became standard.**

*All prior aircraft required retrofit due to engine ice ingestion.*

## MODEL 24B / 24B-A

(13,500 GTOW)  
(12,499 GTOW - 24B-A)

S/N 24B-181 thru 24B-229, except 24-218

Certified in December 1968.

24B-A restricted to 12,499 lbs.

### Notable features:

- Chined nose tires.
- Radome alcohol added; Co-Pilot windshield alcohol removed.
- Electric boot on horizontal stabilizer added.
- General Electric CJ610-6 engines (2950 lbs of thrust).

Changes in model series:

- 24B-181 **Certified for known icing.** Prior aircraft by ECR 770.
- 24B-190 Internal spoiler actuator lock, eliminating old external locking (mouse trap) mechanism.
- 24B-207 Began new style control yokes.
- 24B-210 Flat cabin floor.

**MODEL 24D**

(13,500 GTOW)  
(12,499 GTOW - 24D-A)

S/N 24-218 & 24-230 thru 24-328

Certified in June 1970.

24D-A restricted to 12,499 lbs.

Major Aerodynamic Modifications:

- Tip tanks point down, 2 degrees.
- Bullet nose on vertical removed.
- Removed strake on wing.

Notable features:

- Small cabin windows.
- Flat cabin floor.
- Garrett pressurization module.
- Drag chute available, production option.
- DC torquers installed.
- Riveted tip tanks.

Changes in model series:

- 24-270 Dee Howard Thrust Reversers, optional item.
- 24-272 First executive door (24") installed, optional item.
- 24-297 Variable Displacement Hydraulic Pump (engine driven).

**MODEL 24E**

(12,900 GTOW)

S/N 24-329 and Subsequent.

Certified in June 1976.

Major Aerodynamic Modifications:

- Century III wing on production.
- No fuselage tank.
- Aircraft does not have vertical stabilizer modified for 350 Kt  $V_{MO}$ .*

Changes in model series:

24-350 and subsequent;

Garrett 51,000 ft ECS module.

**Certified to 51,000 ft altitude.**

General Electric CJ610-8A engines installed with new fuel control and tail pipe (2950 lbs of thrust).

**24E-357      Last "24" model built**

**MODEL 24F**

(13,500 GTOW)

(12,499 GTOW - 24F-A)

S/N 24-329 and Subsequent.

Certified in August 1976.

24F-A restricted to 12,499 lbs.

Major Aerodynamic Modifications:

Century III wing on production.

Vertical Stabilizer modified for 350 Kt  $V_{MO}$ .

Changes in model series:

24-350 and subsequent;

Garrett 51,000 ft ECS module.

**Certified to 51,000 ft altitude**

General Electric CJ610-8A engines installed with new fuel control and tail pipe (2950 lbs of thrust).

## MODEL 25

(15,000 GTOW)  
(12,499 GTOW - 25A)

S/N 25-002 thru 25-066, Except 061

**25-065 & -066 never built.**

25-064 modified with 'Longhorn' wing as a Model 28/29 prototype.

Still carries a Model 25 designation as an EXPERIMENTAL aircraft.

Certified in October 1967.

25A restricted to 12,499 lbs.

### Notable features:

Fuselage stretched 52 inches.

Certified to 45,000 ft.

Tip tanks point up.

Bullet nose on vertical.

Straight wing with strake at tip tank.

Old style control yoke.

IDC pressurization module.

General Electric CJ610-6 engines.

### Changes in model series:

25-009 Annunciator panel moved to glareshield.

25-025 Electric Horizontal Stabilizer boot, radome alcohol added.

25-030 Internal spoiler actuator lock, eliminating old external locking (mouse trap) mechanism.

25-032 **Certified for known icing** Prior aircraft by ECR 771.

25-040 New style control yoke installed.

25-046 Flat cabin floor.

## MODEL 25B/C

(15,000 GTOW)

S/N 25-061 & 25-067 thru 25-205

**25-067 thru 25-069 - never built.**

Certified in August 1970.

### Major Aerodynamic Modifications:

Bullet nose on vertical removed.

Removed strake at tip tank.

### Other notable features:

Flat cabin floor.

Tip tanks point down, 2 degrees.

Garrett 45,000 ft pressurization module.

25C - large fuselage tank.

Aux hydraulic pump, *OPTIONAL* item.

The information contained in this training/reference material is not intended to take the place of information found in Learjet drawings, Instructions, Standards or Procedures in the Learjet Service Manuals, Maintenance Manuals, Learjet NDI Manual or FAA Regulations.

Changes in model series:

- 25-121 Dee Howard thrust reversers, optional.
- 25-134 First executive door (24 inch), optional.
- 25-181 Variable displacement hydraulic pump (engine driven).

**MODEL 25D/F**

(15,000 GTOW)

S/N 25-206 thru 25-373

25F model aircraft (large fuselage tank) were never built.

Certified in May 1976.

Major Aerodynamic modifications:

Century III wing, production installed.

V<sub>MO</sub> Increased to 350 kt.

Changes in model series:

25-227 **Garrett 51,000 ft ECS module**

25-230 CJ-610-8A engines (2950 lbs of thrust).

**Certified to 51,000 feet altitude**

25-237, 25-342 and subsequent;

Special Certification Review (SCR) Modification on production.

- two speed trim,
- trim in motion clicker.
- yaw dampener disconnect tone.
- wheel master cut out of all pitch modes.
- nudger added to stall system.

25-290 Softflite on production.

25-363 Full time yaw damper.

**25D-373 Last 25 model built.**

## **MODEL 25G**

(15,000 GTOW)

S/N's 25-337, 25-352, 25-361, 25-370 thru 25-372

The 'G' designation is a marketing designation only. The Certificate of Airworthiness will indicate '25D'. Aircraft is modified with Dee Howard 'XR' modification prior to delivery as new aircraft.

### Major Aerodynamic Modifications, Notable features:

- Wing glove fuel cell.
- Two fences on wing with Boundary Layer Energizers (BLE's).
- Curved strake at tip tank.
- Aft pylon extension modification.
- Curved tip tank fin.
- Flap preselect.
- Increased airspeed limits on flap extension.
- Fuel control/distribution panel.
- Engine stall warning.
- 25-352 and 25-361 have Conrac "-7" stall computer.

## **MODEL 28**

(15,000 GTOW)

S/N 28-001 thru 28-005

Certified in January 1979.

### Major Aerodynamic Modifications:

"Longhorn" wing incorporating Century III.

### Notable features:

- Emergency pressurization override switches.
- Engine stall warning system.

## **MODEL 29**

(15,000 GTOW)

S/N 29-001 thru -004

Certified in January 1979.

### Major Aerodynamic Modifications:

"Longhorn" wing incorporating Century III.

### Notable features:

- Large fuselage tank.
- Aux hydraulic pump, *OPTIONAL* item.

The information contained in this training/reference material is not intended to take the place of information found in Learjet drawings, Instructions, Standards or Procedures in the Learjet Service Manuals, Maintenance Manuals, Learjet NDI Manual or FAA Regulations.

## MODEL 31

(15,500 GTOW)

S/N 31-001 thru 31-034

Four *additional* aircraft have been built and are identified as 31-033A, 31-033B, 31-033C and 31-033D.

Certified August 1988.

### Major Aerodynamic Modifications:

"Longhorn" wing.

Leading edge Boundary Layer Control Devices (BLCD), installed, strips and triangles.

Delta Fins.

Button head screws installed in leading edge at selected locations.

### Notable features:

No Mach trim or puller

No stall pusher.

Single yaw dampener (not required for dispatch).

No spoilers.

## MODEL 31A

S/N 31-035 and subsequent

July 1991.

### Notable features:

Flight Director/Glass Cockpit - total Bendix King.

Digital Nose Steering.

Rudder Boost.

Sierracin electrically heated windshield.

## MODEL 35

(17,000 GTOW)

S/N 35-001 thru 35-066

Certified in June 1974.

### Major Aerodynamic Modifications:

Straight wing, with 24 inch extension outboard of W.S. 181.0.

### Notable features:

Fuselage stretched 12 inches from Model 25 (total of 5' 4" longer than 23 model).

Garrett TFE-731-2 turbofan engine (3500 lbs of thrust).

Garrett 45,000 ft ECS module.

## MODEL 35A

(18,000 GTOW)

S/N 35A-067 and Subsequent  
35-637 - *Converted to* 31-001  
35-666 - Never Built

Certified in April 1976.

### Notable features:

18,300 GTOW option.

### Major Aerodynamic Modifications:

Century III wing on production.

### Changes in model series:

35-107, 35,113 and subsequent; Garrett 51,000 ft ECS module.  
35-154 Aeronca thrust reversers.  
35-265 Additional cabin windows in aft cabin.  
35-279 Softflite on production.  
35-483 Flap preselect.  
35-499 TR-4000, Dee Howard Thrust Reversers, optional.  
35-506 FC-530 (J.E.T.) autopilot on production.  
35-539 Swedlow pre-drilled windshields;  
35-539 thru 35-588; 35-593 thru 35-612; 35-618 thru 35-670  
35-612 Bagged insulation installed in place of sprayed in foam.  
35-671 Sierracin electrically heated windshield, standard equipment.

## USAF C-21A

April 1984

84 Model 35A aircraft by contract;

80 to United States Air Force (USAF)  
35A-509 thru 35A-589

4 to Air National Guard (ANG)  
35A-624, 35A-625, 35A-628, 35A-629

35A-280; US Army

## **MODEL 36**

(17,000 GTOW)

S/N 36-001 thru 36-017

Certified in June 1974.

### Notable features:

Straight wing.

Large fuselage fuel tank.

## **MODEL 36A**

(18,000 GTOW)

S/N 36A-018 and Subsequent

Certified in April 1976.

### Major Aerodynamic Modifications:

Century III wing on production

### Notable features:

Large fuselage fuel tank.

### Changes in model series:

- 36-032 Garrett 51,000 ft ECS Module.
- 36-046 Softflite on production.
- 36-051 Flap preselect.
- 36-058 Bagged insulation installed in place of sprayed in foam.
- 36-063 Pilkington (formerly Swedlow ) pre-drilled windshields.
- 36-064 Sierracin electrically heated windshield, standard equipment.

## MODEL 55

(19,500 GTOW)

(20,500 GTOW; Optional, ECR 2173)

(21,000 GTOW; Optional, ECR 2554/AAK 55-82-3)

(21,500 GTOW; Optional, AAK 55-84-6)

S/N 55-001 thru 55-126

55-002; Modified to a Model "55C" configuration and assigned S/N 55-139A

March 1981

### Major Aerodynamic Modifications:

"Longhorn" wing.

### Notable features:

Garrett TFE-731-3 Turbofan engine (3700 lbs thrust).

### Changes in model series:

55-045 21,000 gross weight, Option.

55-087 Phase 1, Balanced Field Length (BFL) improvement; Boundary Layer Control Device (BLCD) strips, Automatic Performance Reserve (APR) and auto spoilers.  
ER tank.

LR tank option available, Branson STC.

55-101, 55-105, 55-107 and subsequent

Alpha Dot stall warning on production.

Phase 1A, Heavy duty brakes.

21,500 GTOW.

## MODEL 55B

(21,500 GTOW)

S/N 55B-127 thru 55B-134

August 1986

### Notable features:

Glass cockpit.

Collins autopilot.

## **MODEL 55C**

(21,000 GTOW)

(21,500 Optional)

S/N 55C-135 thru 55C-147

September 1988

### **Major Aerodynamic Modifications:**

Delta Fins.

### **Notable features:**

Collins autopilot.

No Mach puller.

No stall warning pusher.

Boundary Layer Energizers on lower surface of horizontal stabilizer.

Single yaw dampener (yaw dampener not required for dispatch).

**55C-147 is the last Model 55 built**

## **MODEL 60**

(22,750 GTOW)

(23,100 GTOW, Optional)

S/N 60-001 and Subsequent

Certified in January 1993

### **Notable Features:**

Fuselage lengthened, 28" in cabin and 14.9" in tailcone.

Pilkington (formerly Swedlow) electrically heated windshield.

Pratt & Whitney engines (PW 305) (4600 lbs thrust).

Rohr thrust reversers.

Collins digital autopilot, 4-tube EFIS and Pro Line 4 Avionics.

Delta fins.

Trailing edge extension on winglets.

Wing leading edge extension cuff at fuselage.

# LEARJET WINGS and WING MODIFICATIONS

## **Straight Wing (20 Series) - 1963**

Droop Leading Edge

Vortex Generators ★

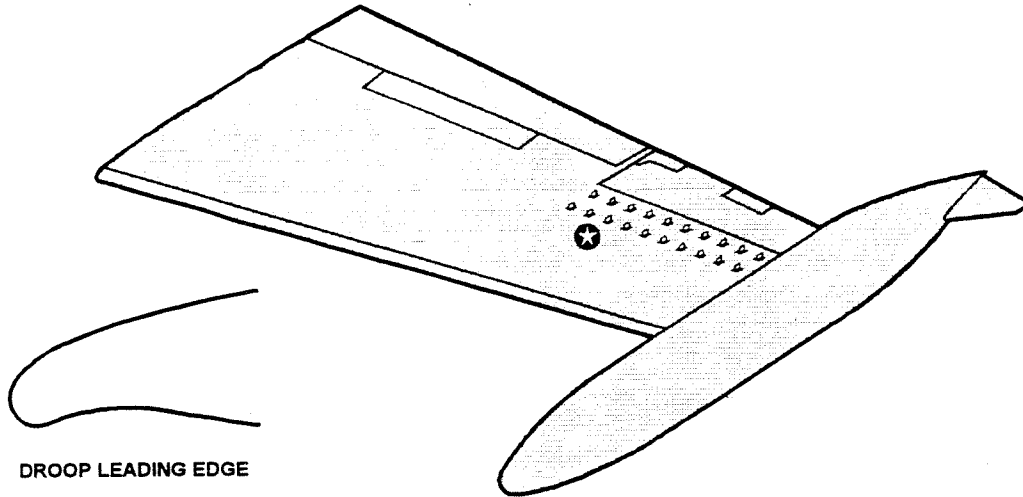

## **Softlite 1 - 1982**

Modified the 20 Series Straight Wing Only.

AAK 82-08, later superseded by AMK 83-4 as a means of compliance of AD 80-19-11.

Replaced vortex generators with Boundary Layer Energizers (BLE) ●

Installed wing fence at WS 125 ◆

Installed Boundary Layer Control Device (BLCD) strips to the leading edge ■

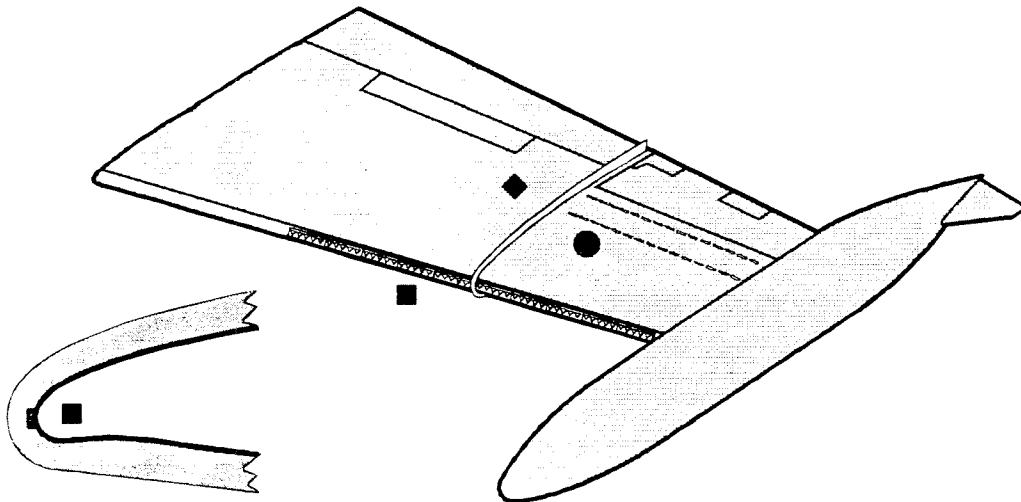

**Straight Wing (30 Series) - 1975**

Droop Leading Edge

Vortex Generators ★

Wing extended by 2 feet, outboard of WS 181

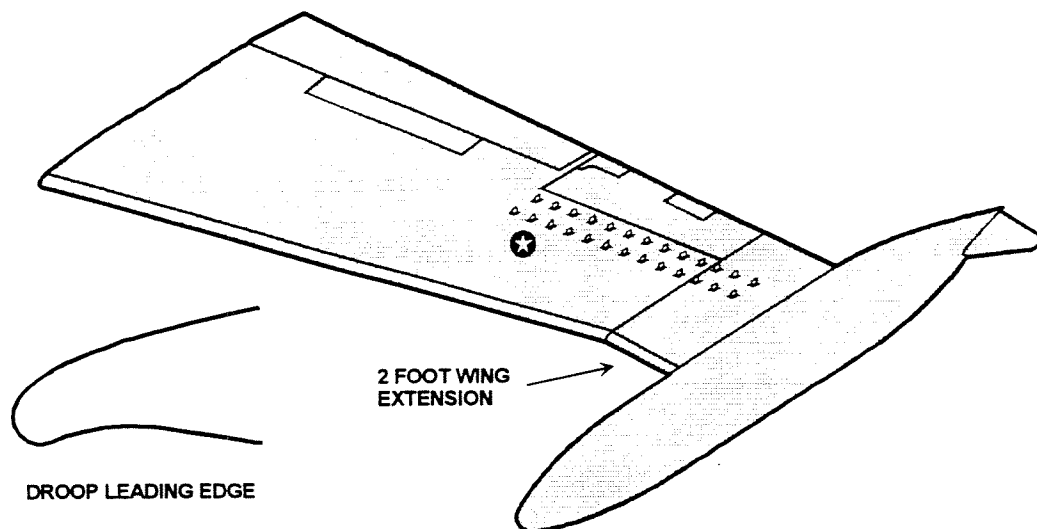

**Century III, Reduced Approach Speed (RAS), 20 & 30 Series - 1976**

Production incorporation at 24-329, 25-206, 35-067, 36-018.

Thicker Leading Edge

Vortex Generators ★

Straight Strake at the Tip Tank ✕

Wing modification installed by AAK 76-4 for in-service aircraft.

23-003 thru 23-099; *when converted to Model 24 configuration.*

24-100 thru 24-328

25-003 thru 25-205

35-002 thru 35-066

36-002 thru 36-017

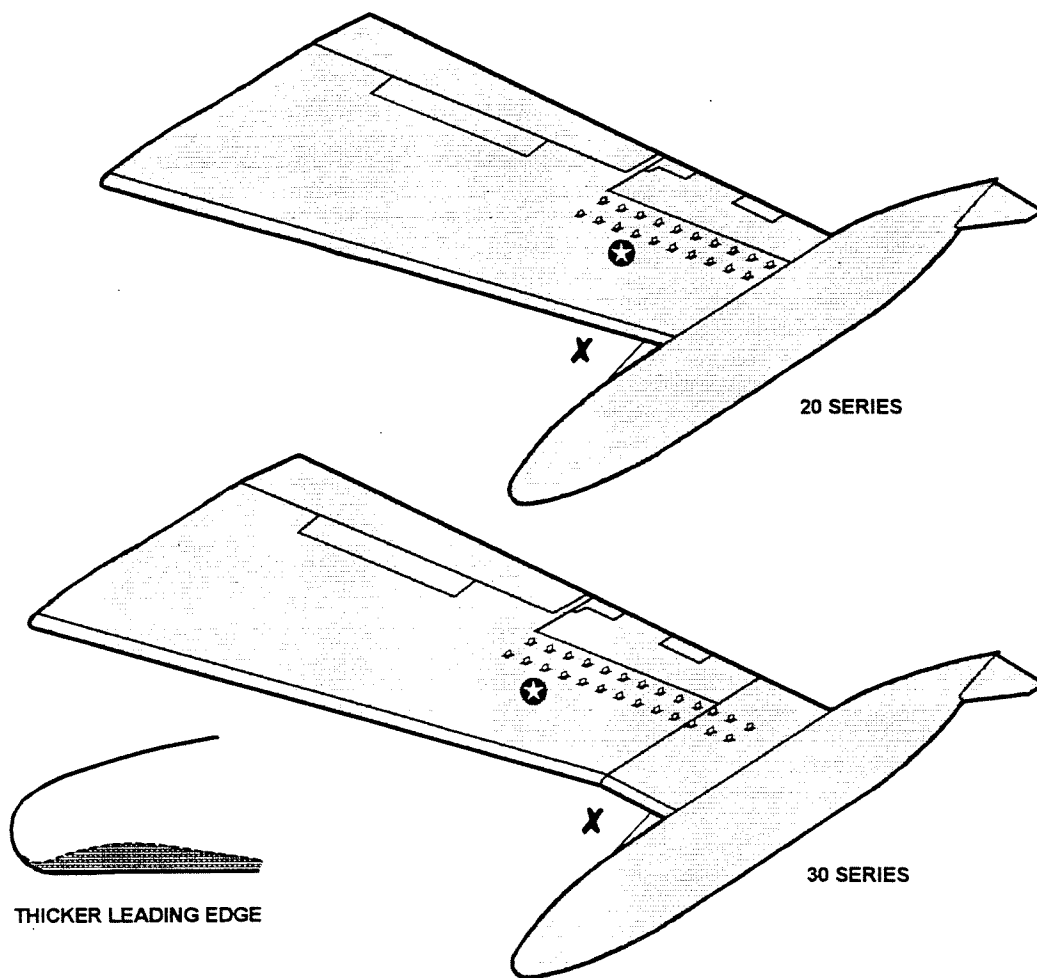

**Sofflite, Century III - 1979**

Sofflite incorporated in production on 25-290, 35-279, 36-046

Installed by AAK 79-10 which was superseded by AMK 83-5 for in-service aircraft with Century III installed.

Replaced vortex generators with Boundary Layer Energizers (BLE) ●

Installed wing fence at WS 125 ◆

Installed leading edge stall strip +

Straight Strake at the Tip Tank ✕

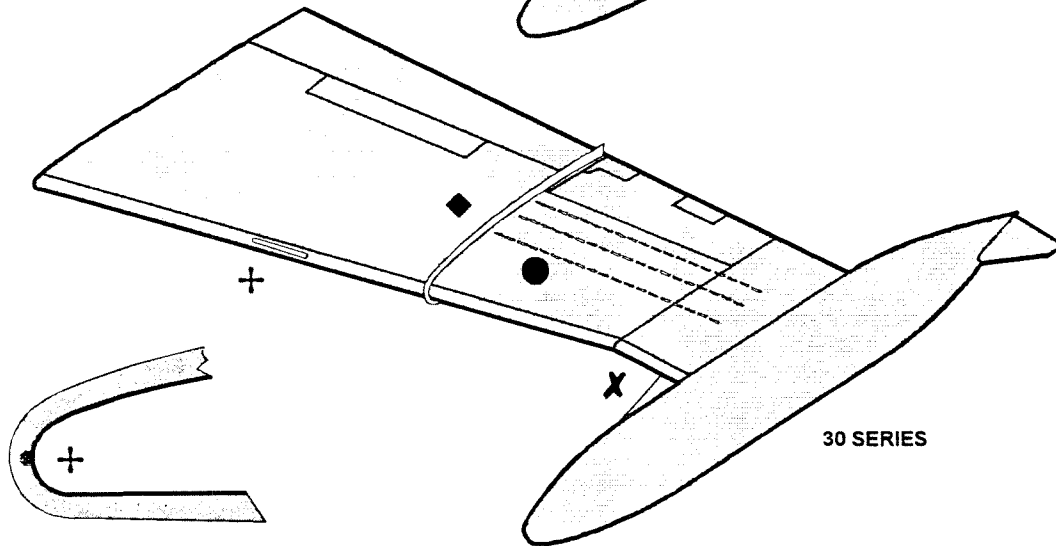
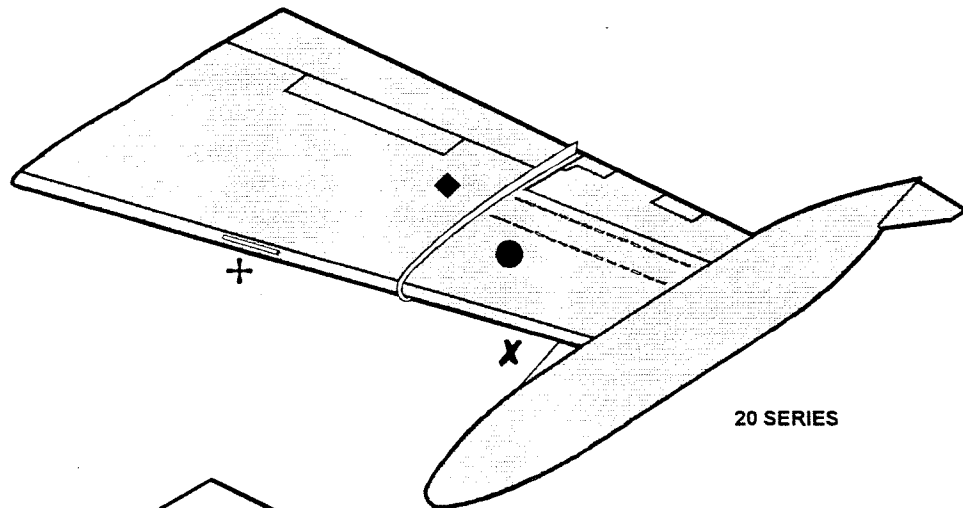

**Longhorn - 1978**

Production incorporated on the Model 28/29 aircraft.

Century III wing

Vortex Generators ✪

Wing extended, with Winglet, approximately 6 feet outboard of WS 181 ★

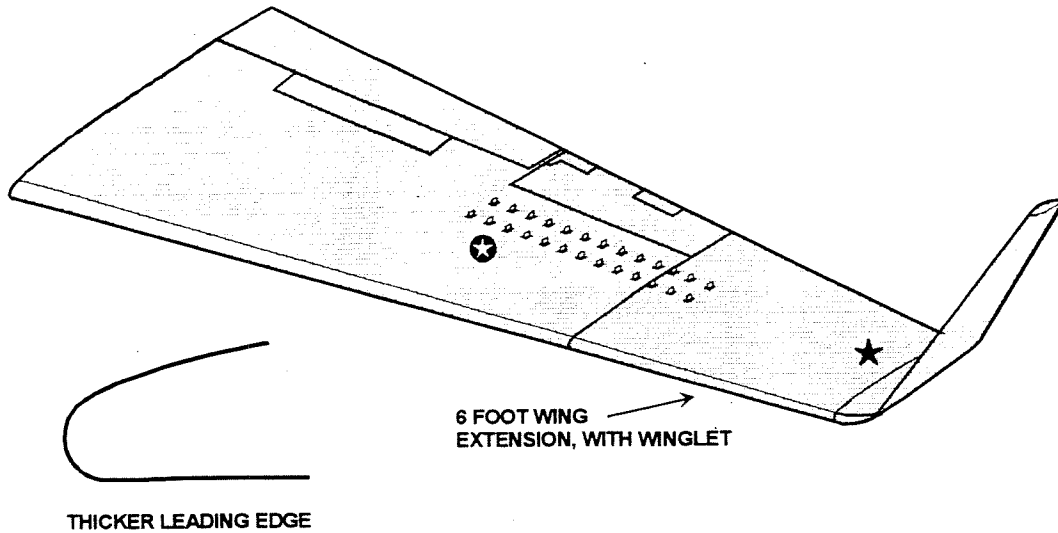

**Softlite, Longhorn**

Incorporated in production at 28-006 and 29-003

Installed by AAK 79-10 which was superseded by AMK 83-5 for in-service aircraft.

Removed Vortex Generators and installed Boundary Layer Energizers (BLEs) ●

Installed Wing Fences installed at WS 125 and WS 185.58 ◆

Installed Stall Strip ✚

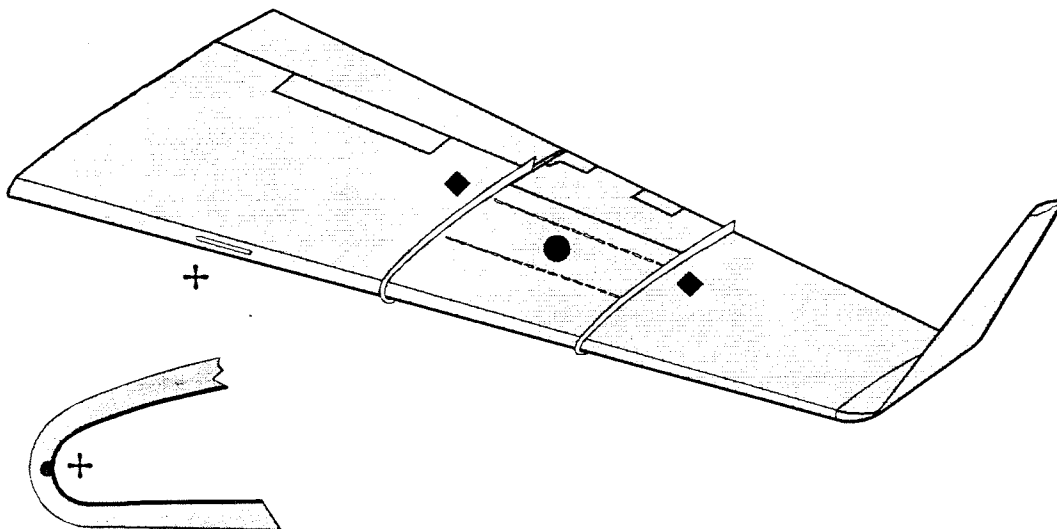

**Model 55 - 1981**

Longhorn wing incorporating softflite

Wing fences installed at WS 125 and WS 185.58 ◆

Boundary Layer Energizers (BLE) ●

Boundary Layer Control Device (BLCD) Strips ■

Stall Strip +

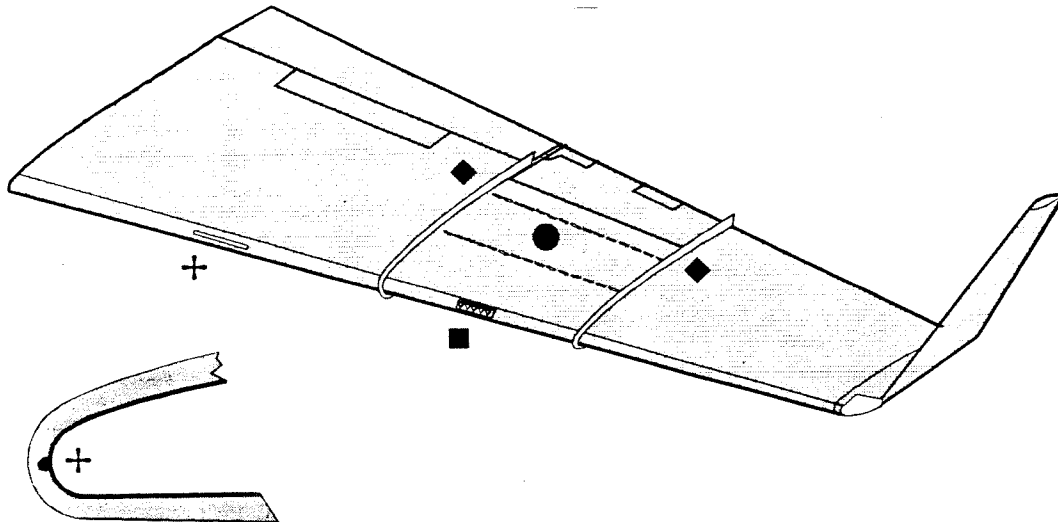

**Model 55, Phase 1**

Wing fences installed at WS 125 and WS 185.58 ◆

Boundary Layer Energizers (BLE) ●

Boundary Layer Control Device (BLCD) Strips ■

Boundary Layer Control Device (BLCD) Triangles ▼

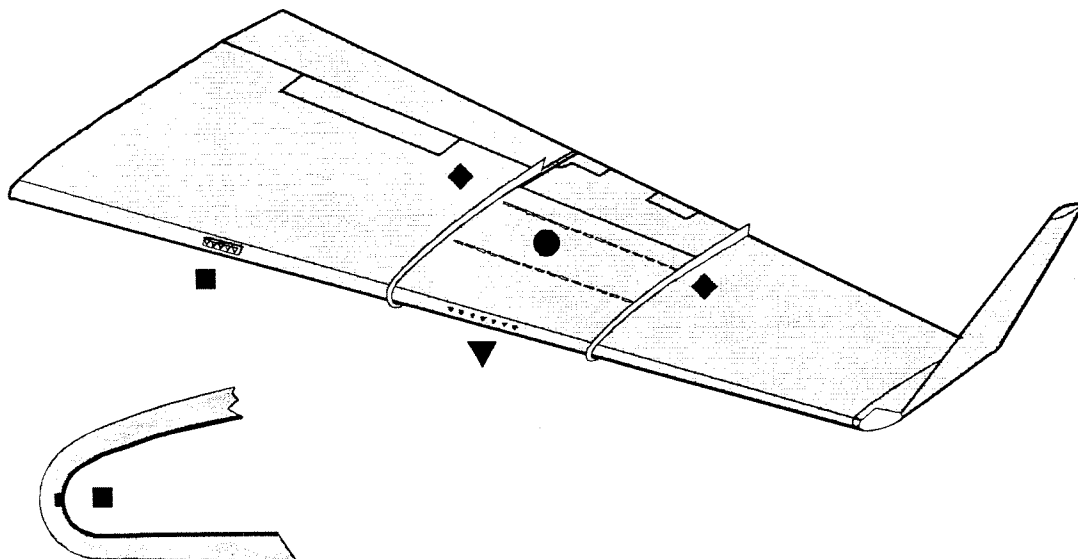

The information contained in this training/reference material is not intended to take the place of information found in Learjet drawings, Instructions, Standards or Procedures in the Learjet Service Manuals, Maintenance Manuals, Learjet NDI Manual or FAA Regulations.

## Model 55C

Wing fences installed at WS 125 and WS 185.58 ◆

Boundary Layer Energizers (BLE) ●

Boundary Layer Control Device (BLCD) Strips ■

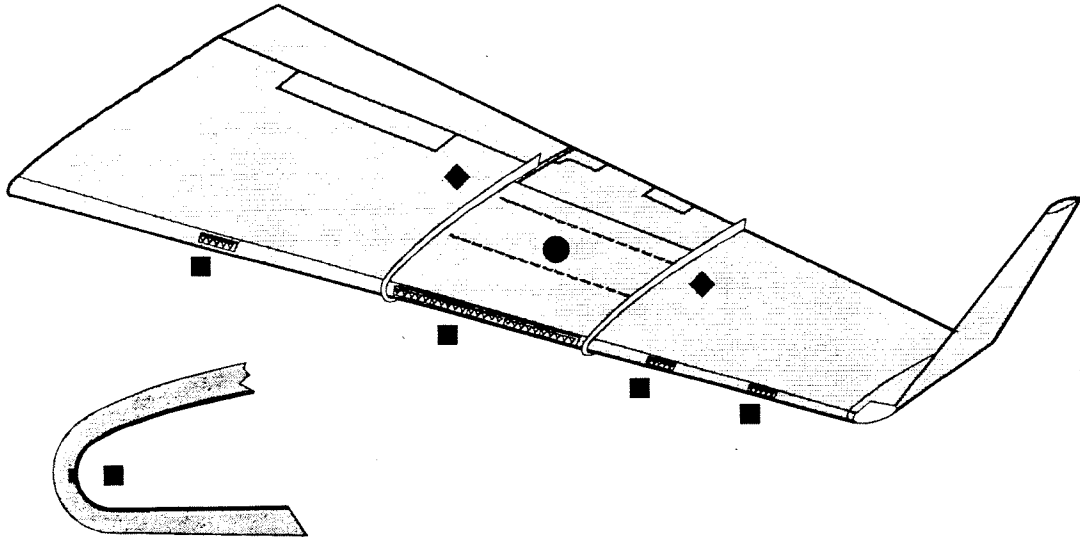

**Model 31 - 1988**

Improved Longhorn wing

Wing fences installed at WS 125, WS 185.58 and a leading edge fence at WS 240.60 ◆

Stall Strip +

Boundary Layer Energizers (BLE) ●

Boundary Layer Control Device (BLCD) Strips ■

Boundary Layer Control Device (BLCD) Triangles ▼

Button Head Screws (in selected locations) \*

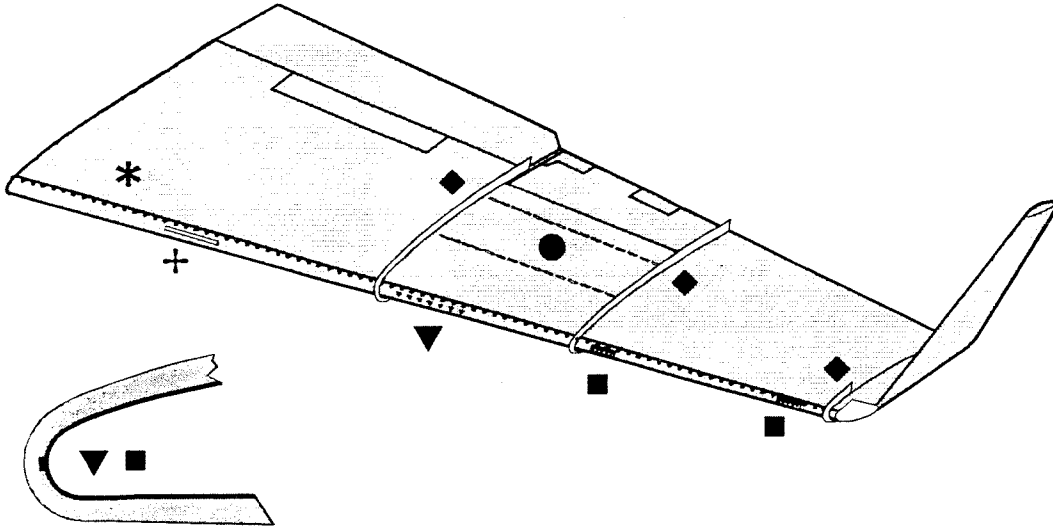

**Model 60 - 1992**

Wing fences installed at WS 125, WS 185.58 and a leading edge fence at WS 240.60 ◆

Stall Strip +

Boundary Layer Energizers (BLE) ●

Boundary Layer Control Device (BLCD) Strips ■

Boundary Layer Control Device (BLCD) Triangles ▼

Button Head Screws (in selected locations) \*

**Modifications to the Model 31 Longhorn wing platform**

Modified Inboard Wing Cuff +

Modified Winglet Design +

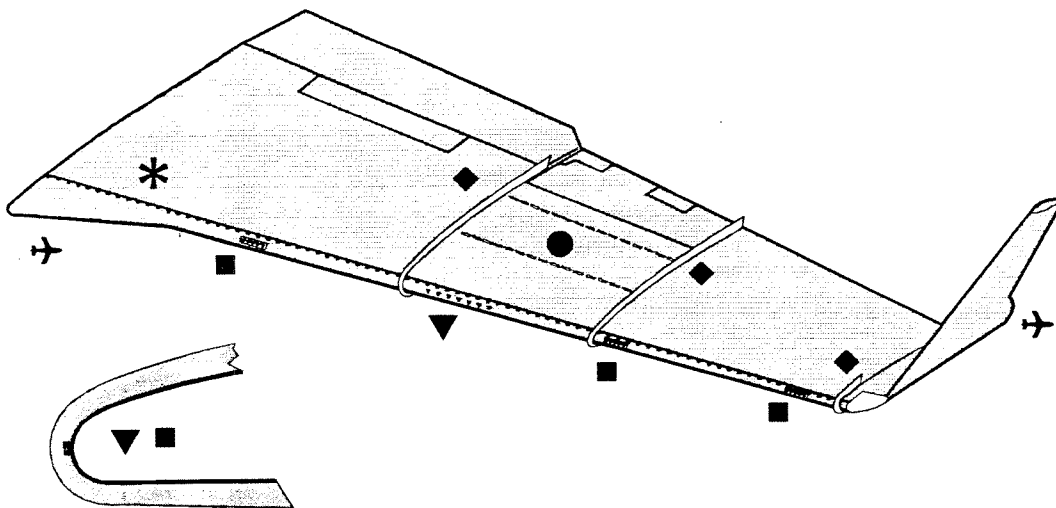

# MODIFICATIONS TO THE LEARJET AIRCRAFT

## 20 SERIES AIRCRAFT

### Dee Howard Mark II

Reduced Approach Speed (RAS) modification. Similar to the Learjet Century III modification.

New contour for wing leading edge and for flap leading edge.

Removes vortex generators

Install large stall strip (triangle) to leading edge

Install curved strake at tip tank

Adds flap pre-select, flap extension distance reduced (shims in actuator)

Increased flap speed limit

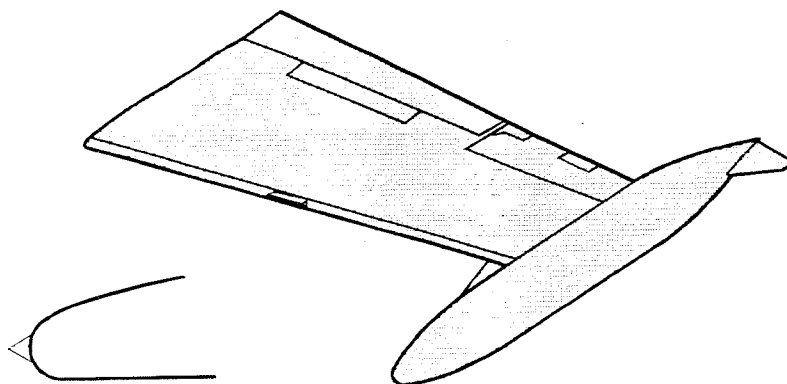

### Dee Howard "XR" Modification (Extended Range)

Wing fuel glove outboard of fuselage, recontours wing platform (with RAS).

Most aircraft do not have Boundary Layer Energizers.

May have one (1) or two (2) stall fences

Curved strake at tip tank

Curved tip tank fin

Aft pylon extension modification

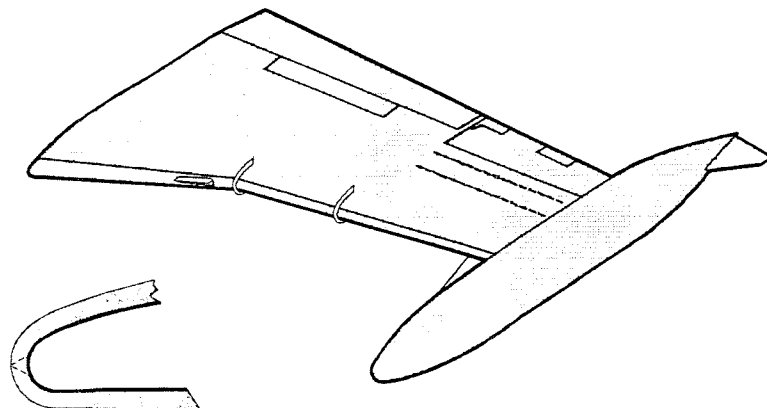

## 30 SERIES AIRCRAFT

### Howard/Raisebeck

Installed on Learjet Century III aircraft only

Installs two (2) large Leading Edge Fences

Installs large Stall Triangle

Installs curved strake at tip tank

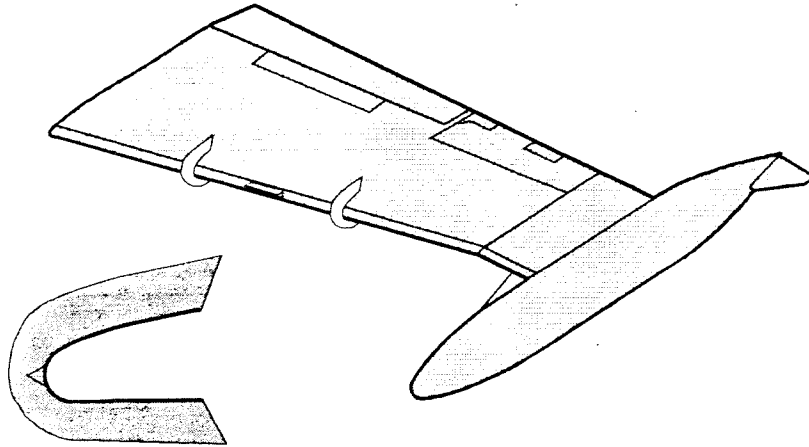

# AIRCRAFT SERIALIZATION

MODEL	PRODUCTION SEQ. S/N's	
23	23-003 Thru 23-099	
24	24-100 Thru 24-180	
24A	24-100 Thru 24-180	
24B	24-181 Thru 24-229	
24BA	24-181 Thru 24-229	
24D	24-230 Thru 24-328	
24DA	24-230 Thru 24-328	
24E	24-329 Thru 24-357	CIII on Production
24F	24-329 Thru 24-357	24-350 & Subq; 51k
24FA	24-329 Thru 24-357	(24-357 - Last Model 24 built)
25	25-002 Thru 25-064, except 25-061	
25A	25-002 Thru 25-064, except 25-061	
	<b>25-065 Thru 25-069; NEVER BUILT</b>	
25B	25-061 & 25-070 Thru 25-205	
25 C	25-061 & 25-070 Thru 25-205	
25D	25-206 Thru 25-373	CIII on Production
25F	25-206 Thru 25-373	25-227 & Subq., 51k ECS 25-230 & Subq., 51 k Certified 25-290 & Subq., SF on Production (25-373 Last Model 25 built)
28	28-001 Thru 28-005	CIII on Production
29	29-001 Thru 29-004	CIII on Production 29-003 & 29-004, SF on Production
31	31-001 Thru 31-034	
31A	31-035 & Subq.	
35	35-002 Thru 35-066	
35A	35-067 & Subq. <i>35A-676</i>	CIII on Production 35-113 & Subq., 51k 35-279 & Subq., SF on Production
36	36-002 Thru 36-017	
36A	36-018 & Subq. <i>063</i>	CIII on Production 36-032 & Subq., 51k 36-046 & Subq., SF
55	55-003 Thru 55-126	
55B	55-127 Thru 55-134	
55C	55-135 Thru 55-147	(55-147 Last Model 55 built)
60	60-001 & Subq	